

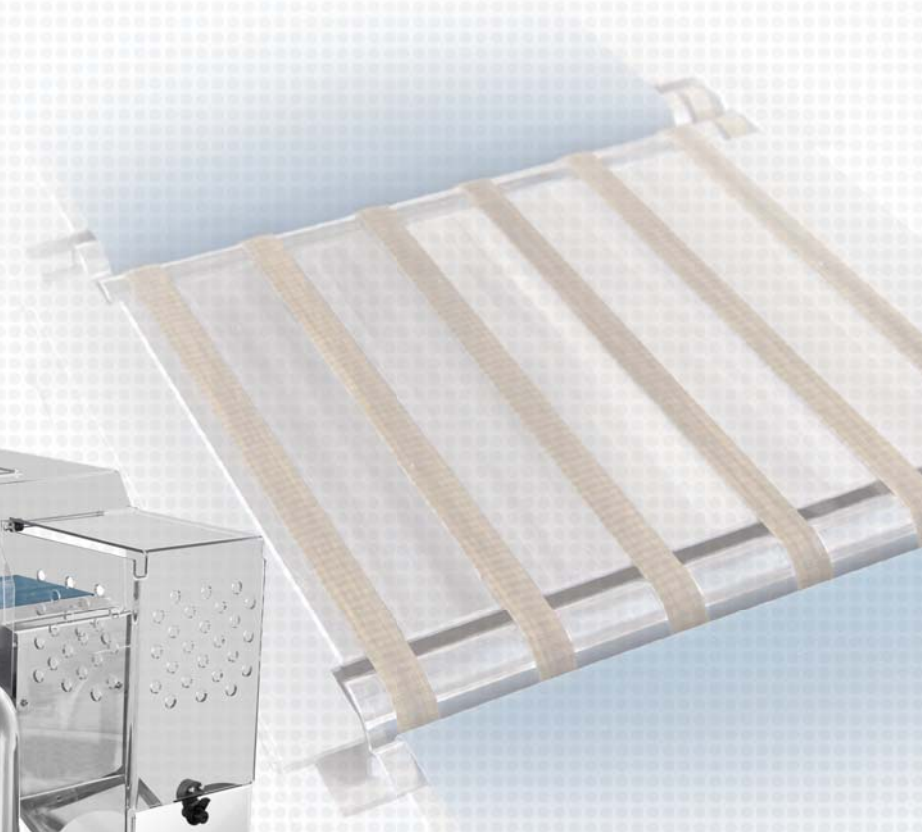

Your partner in inspection and quality control



checkweigher

01D3

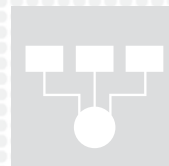

# Your partner in inspection and quality control



go to the web-page dedicated to this product



**PRISMA**

**checkweigher**

**01D3**

## Equipment

- Digital electronics with alphanumeric graphic display
- Electronic self-calibration device
- 3 levels password access protection
- Mobile average function
- 100 storable product programs
- 2 RS232 serial ports
- Production data management in conformity with the standards in force
- Conformity with standards ISO - FDA - HACCP - GMP

## Optional

- Ejection systems
- Reject management systems
- Wind-prevention tunnel
- 24-columns panel printer
- Special conveyors
- Open flap control device
- Separated electronic equipment
- Alarms notification
- Ethernet interface
- USB interface
- Products programs memory expansion
- Feed-back function
- FAT/SAT, IQ/OQ validations
- MID Certification

## Technical Specifications 01D3

Weighing range	up to 600 g
Display division	from 0,1 g
Linear speed	up to 100 m/min
Throughput	up to 500 ppm
Accuracy*	from $\pm 0,1$ g
Pneumatic supply	0,6 Mpa
Air consumption (for ejection)	1 NI
Power supply	230V 50/60Hz single phase
Power consumption	700 W
Mirror finishing of metal parts	Stainless Steel IP54
Climatic environment	from 5°C up to +40°C non-condensing (closed)

\*depending on the weight, dimensions and type of product

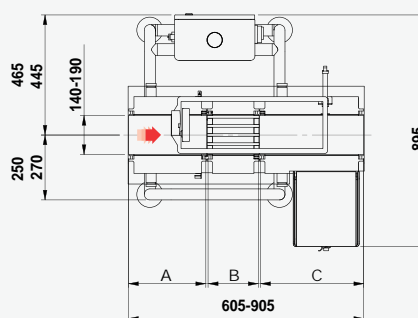
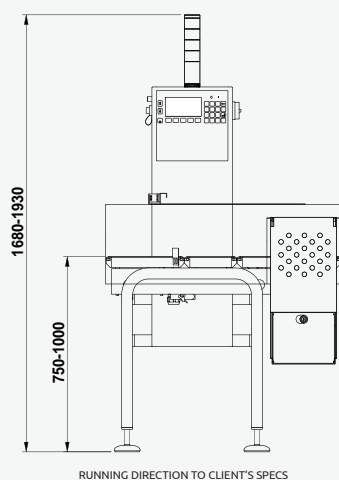

Plates configuration		
Infeed	Weighing	Outfeed
A	B	C
200	200	200
200	300	400
300	200	400



The manufacturer reserves the right to change the product specifications without notice. The image and the drawing are indicative of one of the possible configurations of the machine.

**PRISMA INDUSTRIALE S.r.l.**

Via La Bionda, 17 - 43036 Fidenza - Parma - Italy • Tel. +39 0524 527270 - Fax +39 0524 524142  
www.prismaindustriale.com • info@prismaindustriale.com