

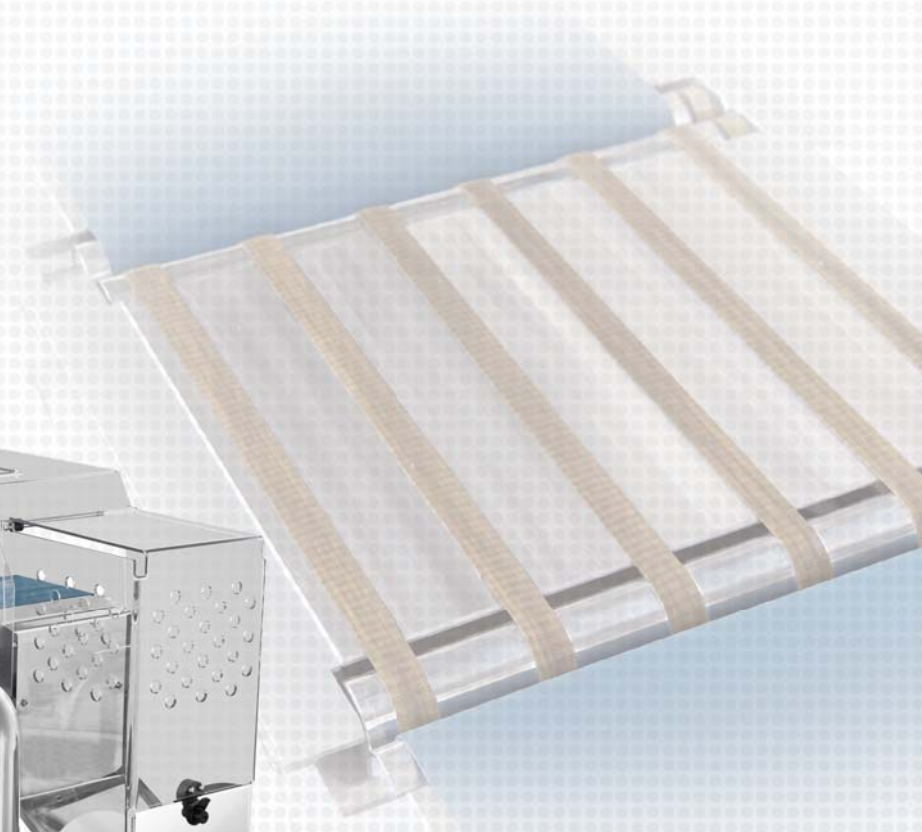

Your partner in inspection and quality control



checkweigher

01W3

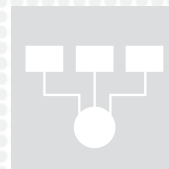

Your partner in inspection and quality control



go to the web-page dedicated to this product



PRISMA

checkweigher

01W3

Equipment

- Electromagnetic load cell
- Digital electronics with PC Mainboard mini-ITX
- 10,4" TFT color display with touch screen panel
- Windows Embedded Operative System
- Electronic self-calibration device
- Mobile average function
- 3 levels password access protection
- 200 storable product programs
- 2 RS232 serial ports
- Ethernet interface
- Conformity with standards ISO - FDA - HACCP - GMP
- Production data management in conformity with the standards in force

Optional

- Ejection systems
- Reject management systems
- Wind-prevention tunnel
- 24-columns panel printer
- Special conveyors
- Open flap control device
- Separated electronic equipment
- Alarms notification
- USB interface
- Products programs memory expansion
- Feed-back function
- FAT/SAT, IQ/OQ validations, CFR21 part 11

Technical Specifications 01W3

Weighing range	up to 600 g
Display division	from 0,01 g
Linear speed	up to 100 m/min
Throughput	up to 500 ppm
Accuracy*	from $\pm 0,05$ g
Pneumatic supply	0,6 Mpa
Air consumption (for ejection)	1 NI
Power supply	230V 50/60Hz single phase
Power consumption	700 W
Mirror finishing of metal parts	Stainless Steel IP54
Climatic environment	from 5°C up to +40°C non-condensing (closed)

*depending on the weight, dimensions and type of product

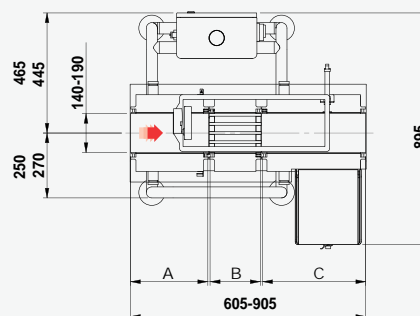
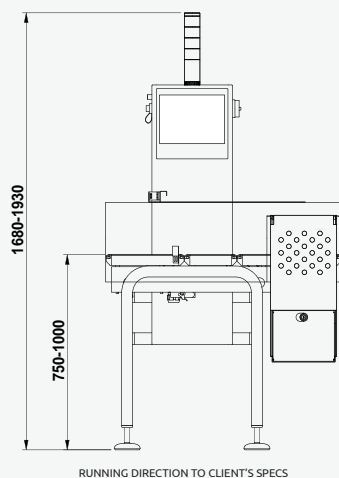

Plates configuration		
Infeed	Weighing	Outfeed
A	B	C
200	200	200
200	300	400
300	200	400



The manufacturer reserves the right to change the product specifications without notice. The image and the drawing are indicative of one of the possible configurations of the machine.

PRISMA INDUSTRIALE S.r.l.

Via La Bionda, 17 - 43036 Fidenza - Parma - Italy • Tel. +39 0524 527270 - Fax +39 0524 524142
www.prismaindustriale.com • info@prismaindustriale.com