

OP-P1BP Single Head Weigher for Vegetables

Optima has designed this machine to weigh fresh vegetables like potato, tomato, vegetable leaves, vegetable salad, etc.

From 2018, we have released our new generation 'plug to run' operation control weigher. In this case, the weigher will auto study the material feeding amount according to the material feeding thickness and vibration to get exact weight. When we run the weigher, just press auto-study for about 2min, the weigher will get good accuracy and speed automatically. For the same material, just change the weight on the screen, all is done, the weigher will run automatically.



OPTIMA

DIMENSIONS

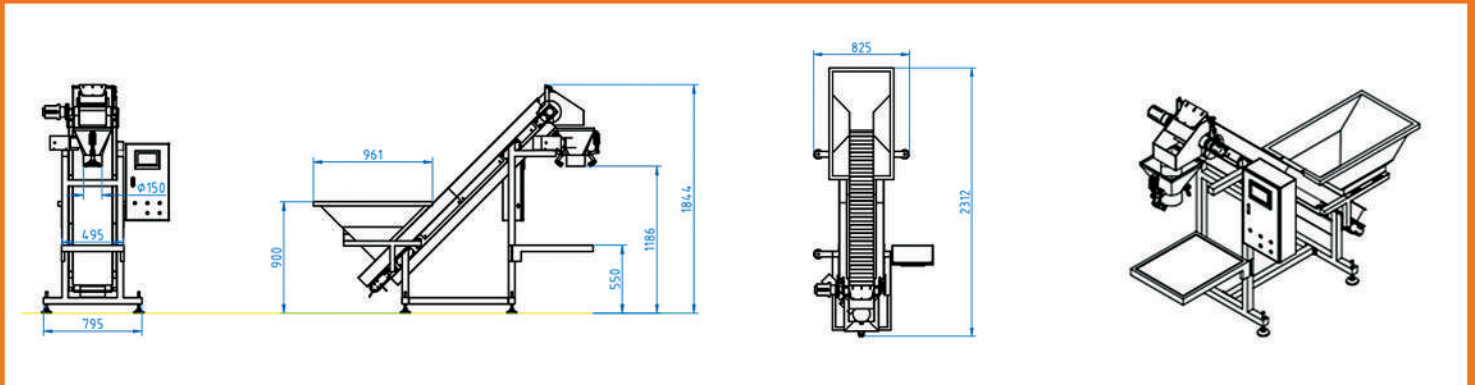

KEY FEATURES

- Full 304SUS building material;
- Bucket capacity 70L
- Compact design with small footprint;
- Customized filling weight
- Double-belted conveyor
- Bag-clamp weighing method
- Support for filled bags
- PLUG-TO-RUN run mode;
- MCU + Touch screen control system;
- Free parameter adjusting during running;

OPTIONS AVAILABLE

- Enlarge size in-feed bunker
- Larger weight load cell
- Enlarge size bag-clamping chute

TECHNICAL SPECIFICATIONS

MODEL	OP-P1BP
Heads No.	1
Weighing Range	1 – 5Kg
Accuracy	1 – 10g
Belt Conveyor	Double-belted conveyor
Max. Speed	1 - 5Bags/min
In-feed Loading Hopper	70L
Control System	MCU+ Touch Screen
Power Supply	AC220V ±10% 50Hz, 1Phase